

## **SIDE STREAM FILTRATION – PROCESS HEATING/ COOLING & HVAC**

The intent of the encompassed articles within this document are for the edification of the Green Tech sales representative with respect to present and future markets of automatic self-cleaning filtration as applied to the process heating/cooling & HVAC industry. This paper should be considered an introductory reading for gaining enough knowledge to engage in an informed discussion with engineers and building managers of how these systems operate and the impact of environmental influences on operational efficiency. This paper also provides examples of actual application(s) that corroborate the effects of side stream filtration along with historical capital & operation costs.

Good luck.

**Steve Fournier, LEED GA**  
District Sales Manager  
John Deere Green Tech



The photograph to the left is a cooling tower located on the campus at Grand Valley State University, MI which is currently under consideration for side stream filtration.

Below we are visiting the mechanical room in the basement of the university to discuss where the new side steam filter can be installed. Chillers, circulation pumps and main piping are located in these physical areas where operational space is a concern.



## PROCESS & COOLING TOWER SIDE STREAM FILTRATION

By: Marcus N. Allhands, Ph.D., P.E. - Application Engineer

### ABSTRACT

The dissipation of ambient or process heat in large HVAC systems, manufacturing facilities, power generation plants, refineries, metal mills and forges, chemical plants and food processors is most often accomplished by cooling towers. These simple structures facilitate the transfer of unwanted energy (heat) from a transport liquid (usually water) to the atmosphere. The bane of cooling towers, with relation to efficient heat transfer and pathological risks to employees, is suspended solids. These solids can originate in the process, in the piping, from the atmosphere or from internal biological growth. Side-stream filtration is the most commonly used method of maintaining minimal suspended solids in the cooling system. Present-day systems rely mainly on two established methods of suspended solids removal. The first utilizes cyclonic principles that are highly efficient at removing high specific gravity solids. The other method is granular media filtration that is generally efficient at removing low specific gravity organic solids. Automatic self-cleaning screen filter technology not only removes both organic and inorganic solids regardless of specific gravity but also requires very little energy to operate and conserves coolant additives by using very little coolant liquid for the self-cleaning process. By incorporating the cleaning cycle into the blow-down process of the cooling tower system, the unwanted loss of any coolant can be completely eliminated.

### INTRODUCTION

Open cooling systems are composed of a cooling tower, a basin, pumps and a heat source. A cooling tower is an enclosed device using air to cool water by evaporation; thus, the atmosphere becomes the heat sink. Cooling towers are generally of two basic types: natural draft and mechanical draft. The former depends upon natural atmospheric conditions to move air through the tower while the latter uses mechanical fans to move air through the tower. Mechanical draft can be either forced-draft design where air is *pushed* through the tower by fans located near the incoming air or induced-draft type where air is *pull* through the tower by fans placed in the air exiting the tower. The basin is generally located beneath the cooling tower to catch and contain the cooled water, accommodate liquid expansion and contraction, serve as a reservoir for the storage of surplus water, and act as the sump for the cooling system pumps. The pumps move heat through the system by circulating cooled water to the heat source where heat is absorbed. Flow continues, moving the heated water back to the cooling tower where the heat is transferred to the atmosphere. The heat source is where the water picks up the unwanted energy in the form of heat. This is often accomplished by direct contact between the water and the source of heat, as when hot steel is cooled during the rolling process by being sprayed directly with the cooling water. Another means of removing heat from the source is by the exchange of heat energy across a solid medium such as in a heat exchanger. Here another liquid in a closed system transfers the heat energy from the source to the cooling water by conduction through metal plates or the thin walls of metal tubes. No physical mixing occurs between the water in the open cooling system and the liquid in the closed loop system.

11/24/2010

## PROBLEM

The presence of suspended solids in a cooling water system can cause problems in each of the system components. The loss of heat transfer efficiency in any component of the cooling system necessitates a higher flow of water to remove heat at the required rate; thus, incurring more energy costs for more pumping capacity. Nozzles in counterflow cooling towers have very small orifices and can become easily plugged with organic or inorganic debris. This results in irregular distribution of water across the tower cross-section. This can lead to uneven cooling and loss of efficient transfer of heat to the atmosphere. Many towers contain packing to form a thin liquid film increasing the surface area of the water/air interface for more efficient heat transfer. Suspended solids can block passages in this packing thus decreasing the surface area for heat transfer and forming a more conducive substrate for the growth of biological materials such as algae, mosses, and even pathogens.

Solids in the basin present other problems. The simple fact that settled solids take up volume requires periodic shut-down of the system for cleaning. Unscheduled shut-downs can be very expensive, especially if production is lost. Accumulated sediments also provide protection, nutrients and a habitable environment for algae, bacteria and other organisms; including pathogens such as *Legionella pneumophila*.<sup>1</sup> These sediments can insulate the basin walls from treatment chemicals such as corrosion inhibitors and oxidizers. This can lead to unexpected basin failure in metal towers.

Abrasive solids can cause accelerated erosion of pumps. This can lead to frequent repairs and premature capital replacement costs. In addition to pumps; piping, valves, fittings, heat exchangers and other mechanical parts may need frequent repair or replacement when abrasive solids are present in the system.

If the water in the system absorbs heat from a heat exchanger, it is very important to keep the fouling factor as small as possible. Table 1 shows that a 0.001 increase in the fouling factor of a heat exchanger surface can increase overall energy consumption by 10%; thereby, increasing operational costs.<sup>2</sup> The fouling factor can be caused by inorganic particles, organic particles such as algae and bacteria or various slimes produced by a number of organisms found in cooling water or on the surface of the components of the cooling system. Flow velocities often decrease inside a heat exchanger allowing heavy particulates to settle out. This accumulation of sediment inside the device will not only decrease its efficiency but will also require additional maintenance or early replacement. Heat source processes that involve spray nozzles are particularly susceptible to suspended solids impact. If the orifice in any of these nozzles becomes plugged, the process will be impaired. Other processes involving direct contact between the cooling water and a product may include quenching operations. Solids can settle in the quenching tank and present various problems including those discussed concerning cooling tower basins. Solids in the cooling water can also affect the surface finish on some products making them functionally or aesthetically unsuitable.

The entire water volume in an open cooling system can be affected by suspended solids. These particles, even in suspension, can provide a substrate for microscopic organisms to grow and multiply. Certain chemicals are necessary for the proper maintenance of the water in an open cooling system. These include biocides for the control of pathogenic and nonpathogenic organisms. Organic matter in the form of suspended solids will utilize a large amount of the biocides. Inorganic suspended solids can also tie up biocide molecules by simple surface adhesion. Corrosion inhibitors and polymers are chemicals added to prevent or slow the progress of rust and to keep dissolved solids in solution. Suspended solids can tie up these chemicals requiring the addition of more than expected amounts to maintain specific concentrations in the water volume; again, increasing operational costs.

11/24/2010

Organic solids are added to cooling towers by birds, insects and wind-blown debris such as pollens and seeds (think cotton wood tree seeds). Other organics grow throughout the open cooling system in the form of algae, mosses, bacteria, slimes and other organism. Inorganic particles can precipitate out of the raw water in the form of various carbonates, phosphates, silicates and others. Rust flakes can break off the walls of the piping in the system and add to the particulate load. The heat source itself can add particulates, especially if the cooling water comes in contact with the heat source as in quenching and de-scaling operations. However, in most cases the majority of suspended solids come from the atmosphere in the cooling tower itself. Wind blown debris can be carried for miles from sources such as streets, gravel access roads, nearby manufacturing facilities, surrounding farm land and livestock facilities.

It is apparent that suspended solids and other particulates must be removed from the cooling system if operating costs are going to be kept to a minimum. Another benefit for removing suspended solids is the reduction of the use of chemicals in these systems.

#### AVAILABLE SOLUTIONS

There are a number of means available to remove solid particles from a cooling system. They can be classified into three basic means: physical, dynamic and filtration. The simplest physical means is inherent with most cooling systems. Because cooling towers are evaporative in nature, dissolved solid concentrations will continue to increase in the volume of water left in the system as pure H<sub>2</sub>O leaves the tower in the form of vapor escaping to the atmosphere. A high concentration of dissolved solids leads to accelerated corrosion and other process problems. By wasting a certain volume of water from the system to a drain and replenishing it with fresh raw water, the cooling system water is diluted resulting in a lower dissolved solids concentration. This "blowdown" water also flushes out a certain amount of suspended solids and particulates, thus removing solids from the system. Another inefficient and costly (but often used) means of physically removing solids from a cooling system is by "armstrong." Maintenance personnel using "strong arms" simply shovel out the solids deposited in the cooling tower basin every few months.

The second method of solids removal from a cooling system makes use of the dynamic forces in the system. These devices are typically referred to as centrifugal separators, cyclonic separators or hydrocyclones. Whatever term is used, they cause the water to flow in a tight circular pattern inside a cylindrical separation chamber. The inertia of the solid particles forces them to the outside of a separation chamber where they slide to the bottom of the device and are collected while the water works its way up the center of the chamber and out a discharge port near the top.

Filtration methods operate by a number of mechanisms and come in many different configurations. Bag filters operate, for the most part, on the principal of two dimensional surface straining. They are made from fabric, either woven or nonwoven and have holes of a certain size that either block the passage of particles too large to pass or allow particles smaller than the holes to pass through along with the coolant. The general construction of these filters is a pressure vessel containing one or more bags with flow generally going from the inside of the bag to the outside. Similar to bag filters are cartridge filters. These cylindrical elements are also placed in a pressure vessel. However, cartridges add a third dimension to the filtration process since their media have significant depth. They not only act as strainers or sieves (surface filtration) but also capture particles by entanglement, impingement and entrapment within the depth of the cartridge.

Granular media filters are often referred to as sand filters. They use single or multiple layers of silica sand, anthracite, garnet or simple gravel media in a pressure vessel. As water flows through the media, suspended solids impinge upon or get entrapped by the granules. Gravity sand filters have been used for at least two millennia for water purification.

11/24/2010

The final form of filtration used in cooling tower systems is screen filtration. These filters typically incorporate two dimensional surface filtration principals. The cooling water passes through wedge-wire, woven-wire or perforated cylindrical elements with solid particles retained on the screen surface that are too large to pass through. This type of filter can be a simple manually cleaned basket strainer or a fully automatic self-cleaning unit.

All the solid removal systems described above with the exception of the physical methods can either be installed as full flow or side-stream systems. In the case of full flow, the removal system is placed in the piping leaving the pumps on the way to the heat source; thereby, seeing the full flow of the circulation system as shown in Figure 1. Because unexpected repairs may be necessary to the filtration system, there should always be a by-pass to the filters to maintain cooling water flow at all times. Side-stream systems only see a portion of the flow. The needs of the particular application will determine which is used. If orifices, such as those in spray nozzles, are to be protected from plugging in the cooling tower or the process at the heat source, then full stream protection is recommended to remove *all* particles large enough to cause a single nozzle to plug. There is a probability that a number of hard inorganic solid particles could reach the orifice at the same time and bridge across the orifice opening even though each individual particle could easily pass through the opening. For that reason, the filtration degree of the solids removal system for hard, three dimensional inorganic particles should be on the order of 1/5 to 1/3 the diameter of the orifice. Since organic materials tend to be somewhat sticky in nature and can slowly build up along the orifice edges with time, the filtration degree of the solids removal system should be 1/10 to 1/8 the diameter of the orifice. University of Florida studies have confirmed these figures and decades of field experience in applications around the world have lead to this postulate.

Most filtration systems for removing suspended solids from a cooling tower are side-stream systems because of lower capital costs. One method is to take a percent of the flow downstream of the pumps and then deliver the filtered water back to the full flow stream with the aid of a booster pump.

Figure 2 shows this type of side-stream system.

Another method of side-stream filtration takes a percent of the flow downstream of the pumps and then delivers the filtered water back to the tower basin. This method requires no additional pumps; however, it may affect the flow rate and/or pressure of cooling water sent to the heat source. See Figure 3.

The third side-stream system is to draw water from the tower basin with a dedicated pump and then discharge the filtered water back to the basin as shown in Figure 4. Since this method requires its own pump, control valves and controller, it lends itself to self-contained skid construction. Installation is quick and simple and the system is easily moved from site to site. Side-stream filtration will not give 100% protection if orifice blockage in the process or in the cooling tower is a concern. It is designed to keep the suspended solids within a range of steady-state conditions. The latter two side-stream systems may or may not aid in keeping the basin floor clean. To accomplish this, the hydrodynamic conditions of the basin itself must be evaluated taking into account the shape and depth of the basin as well as the flow rate of the side-stream system and the distribution of return water from this system. For basin cleaning the return water from the side-stream system must be distributed in such a way as to "sweep" debris from the basin bottom to the filtration system pump inlet so that it will pass through the filter for removal. Side stream filtration systems are sometimes designed to handle a certain percent of the cooling system's full flow. This percentage can vary anywhere from 1% to 20% depending upon many factors such as degree of protection required, type of material being removed, concentration of suspended solids and the method of filtration. Some side-stream filtration systems are designed to pass a certain number of cooling system volumes per day, or "turnovers." ***The number of turnovers are often 8 to 10 for a side-stream filtration system.***

## DISCUSSION

The amount of suspended solids removed from a cooling system by simple blowdown is usually less than the amount of suspended solids being added by the various means previously discussed. This can be looked at as a supplemental means of controlling suspended solids but not the primary means. The “armstrong” method of controlling cooling water debris will remove heavy solids that have already dropped out of the water flow but does nothing for suspended solids still in the water column or already deposited in tower packing or on heat exchanger surfaces. Very few organic solids will be removed by this method other than what can be scraped off the basin walls and floor.

Dynamic methods of removing undissolved solids from cooling systems using cyclonic separators rely on the difference between the specific gravity of the particles and that of water. The greater the specific gravity of the particles to be removed and the larger their size, the greater is the removal efficiency. For instance, for particles with a specific gravity of 7.5 one can expect 80-90% removal of particles greater than 40 micron in diameter. However, at a specific gravity of 1.7 the removal efficiency falls to between 15-40%.<sup>3</sup> Bear in mind that most organic matters found in cooling systems have specific gravities of about 1. Pressure loss across these devices typically runs 0.3–0.8 bars ( 5-12 psi ). Flow through a cyclonic separator must be maintained within the design flow rate  $\pm 25\%$  to operate efficiently. Since they have no moving parts other than a manual or automatic valve to periodically flush the debris from the collection chamber, they have good longevity and require few repairs.

Whereas cyclonic separators operate under a constant pressure drop for a given flow rate, bag filters cause the pressure drop to increase as more and more debris is captured until the bags are cleaned or replaced. When the pressure loss across the bag system reaches a threshold level, the filter vessel is isolated from fluid flow and pressure, opened, and the dirty bags manually removed and replaced with new ones. The pressure drop across a bag filter can run from 0.14 bars (2 psi) with clean bags to over 2 bars (30 psi) when dirty. Care must be taken to not rupture the bag during the filtration process. Bag filters can be very effective at removing particles in the 5-200 micron range. When using bag filters, very little water is lost. Only what is absorbed in the dirt on the bag leaves the cooling system.

The third dimension of cartridge filters adds dirt holding capacity and surface area to the system allowing them to stay online longer than bags of the same filtration degree and relative overall size. Cartridge filters are used where very fine filtration is required, generally between 0.5 and 50 microns. Pressure losses across cartridges can run from 0.35-3.4 bars (5-50 psi) with flow going from outside the cylindrical element to the inside. Like bags, the filter vessel must be isolated from fluid flow and pressure, opened, and the dirty cartridges manually removed and replaced with new ones. Both bag and cartridge filters require labor for replacement.

Sand media filters require a routine media replacement since the filter media through agitation wear and become less efficient at removing particles. When trapped solids from the water cause the pressure drop through the sand media to reach a certain level, the filter is taken offline and the direction of water flow is reversed with sufficient flow rate to expand the media volume, separating the sand particles, and flushing the debris from the vessel into a drain. After sufficient flushing, the flow is reversed and the vessel put back online. These filters require an outside source of clean water for flushing with sufficient flow rate to cause media expansion. Generally this back-flushing flow rate is 1.1 to 1.8 times the filtering flow rate.<sup>4</sup> Sand media filters must also be taken offline for the cleaning process to occur. This takes from 3 to 10 minutes to complete. The back-flush cleaning process also causes the sand granules to abrade one another knocking off the sharp edges that allow the granules to catch and hold on to organic solids. There are a few proprietary sand media filters that involve a constant flushing process to keep them online at all times but much more water, along with chemicals, is lost from the cooling system and they are generally more expensive than other sand media filters.

Sand media filters can be very heavy requiring them to be mounted on a concrete pad with an appreciable footprint. Pressure loss across these filters ranges from about 0.7 bars ( 10 psi ) when clean to 1.4+ bars ( 20+ psi ) when cleaning is required. Trapped particles with specific gravities greater than the granular media, about 2.6 for silica sand, and diameters about the same as the media grains will accumulate in the vessel and may require the media to be replacing periodically. However, these filters are very efficient at removing lighter organic material from cooling water. As water passes through 0.4-0.6 meters ( 18-24 inches ) of sand, organic particles are fixed by flowing into dead-end passages, impinging upon single jagged sand grains, by sieving action when they are too large to pass through the openings between sand grains and some simply adhere to the surface of individual sand grains. The filtration degree of sand media filters depends on the type and grade of granular media. Media is available to remove particles as small as 0.5 micron but more commonly used media in sand filters are rated 10-40 microns.<sup>2</sup>

Basket strainers typically remove only large particles since they are likely to have perforated screen elements with holes 3000 microns and larger. They are relatively inexpensive to purchase and install but can be labor intensive under high load circumstances since they must be manually cleaned. Many filter manufacturers make manual screen filters that are mounted in-line with the piping and have cylindrical screens with filtration degrees down to 80-100 microns. Again, these require labor for maintenance. Automatic self-cleaning screen filters will be discussed later in this manuscript.

#### NEWER TECHNOLOGY

Automatic self-cleaning screen filters are relatively new compared to cyclonic separators and sand media filters. Over the past two or three decades a number of manufacturers have developed automatic screen filters for the removal of suspended solids from pressurized water streams. Woven-wire technology has provided screens with maximum open areas and filtration degrees down to 10

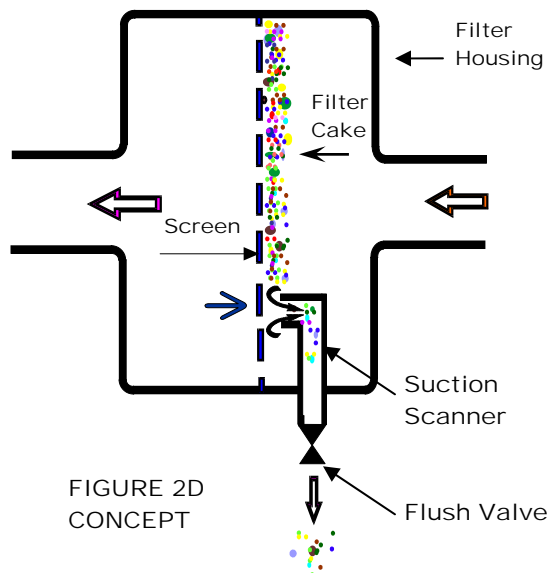

microns. By providing a two dimensional discrete opening, particles are positively removed based on size alone and not other characteristics such as specific gravity, shape or particle plasticity. This makes screen filters a good choice for the protection of orifices in full flow situations. Automatic self-cleaning screen filters remove organic and inorganic particles with equal efficiency. The removal efficiency is not dependant upon a probability function but is positive in nature. The pressure drop across the filter stays between 0.07 and 0.14 bars ( 1 and 2 psi ) most of the time with maximum drops reaching 0.5 bars ( 7 psi ) across the screen very briefly before initiating the automatic cleaning cycle. This can be an adjustable parameter for those existing applications with sensitive equipment losses. The filter remains online and filtering during the entire cleaning cycle which takes 12- 40 seconds to complete. The total volume of water used for cleaning is quite small, usually <1% of total flow.

As seen in the Figure 2D when the flush valve opens to atmosphere a low-pressure area is created at the nozzle tip of the suction scanner creating a high velocity vacuum. Simply, the difference between the higher pressure inside the housing of the filter and atmosphere causes this effect. The scanner assembly is then moved across the entire surface of the filter element for a 100% cleaning.

11/24/2010

Expanding on this concept shown in Figure 5, during the cleaning cycle, unfiltered water flows into the filter through the inlet flange of the filter body. Water then proceeds through the multi-layer cylindrical stainless steel weave-wire screen from the inside out causing particles larger than the filtration degree (pore size) of the screen to accumulate on its inside surface. When a 0.5 bars ( 7-psi ) pressure differential is reached across the screen due to debris build-up, the filter begins a cleaning cycle. During the cleaning cycle, there is no interruption of flow downstream of the filter. The filter operation and cleaning cycle is controlled and monitored by a Programmable Logic Control (PLC). During the cleaning cycle a device called a suction scanner rotates while threads on its drive shaft pass through a fixed threaded bearing adding a linearly motion to the rotation inside the cylindrical screen. The exhaust valve opens connecting the inside of the suction scanner to atmosphere. Nozzles branch from the central tube of the suction scanner with openings only a few millimeters from the screen surface. The differential gauge pressure between the water inside the filter body ( 2.4-10.2 bars or 35-150 psig ) and the atmosphere ( 0 bars gauge ) outside the filter body creates high suction forces at the openings of each of the suction scanner nozzles. This suction force causes water to flow backward through the screen at nearly 15 m/sec ( 50 ft/sec ) in a small area at each nozzle pulling the filter cake off the screen and sucking it into the suction scanner and out the exhaust valve to a waste drain. The electric driving mechanism then rotates the suction scanner at a slow, fixed rate of 24 rpm while simultaneously moving the scanner linearly at a fixed speed. The combination of rotation and linear movement gives each suction scanner nozzle a spiral path along the inside surface of the filter screen. The cleaning cycle is completed in 10 to 40 seconds depending on filter model, during which time the nozzles remove the captured debris from the entire filtration area of the filter screen.<sup>5</sup> This volume acts as supplemental blow-down for the system to keep dissolved solids within acceptable limits.

#### Case Study 1<sup>6</sup>

Nucor Steel in Crawfordsville, Indiana installed over \$1M in chillers for their cold mill process. Water feeding the chillers came from a large cooling tower at a flow rate of 615 m<sup>3</sup>/hr (2700 gpm) and 5.1 bars (75 psi). The facility is located in a rural area with fields of soybeans and corn completely surrounding the site. This setting caused mass amounts of organic and inorganic wind-blown debris to be deposited in the cooling tower basin. The original design called for the installation of manual basket strainers in the feed line to the chillers with 1.5 mm openings. When storm events occurred, a plumber would clean the basket strainers manually as often as every three hours. A single automatic self-cleaning filter with a 100 micron (0.004 in.) weave-wire screen was installed in 1997 to filter the entire flow to the chillers. The filter has been operating around the clock for seven years now with no routine labor.

#### Case Study 2<sup>7</sup>

Noranda Aluminum in New Madrid, Missouri cast aluminum billet (aluminum round bar) using direct chill casting technology. Noranda's Casthouse produces several different size billets ranging from 125 to 305 mm (5 in. to 12 in.) in diameter. The casting tooling will pour between 32 and 90 billets at a time depending on billet diameter. During the direct chill casting process cooling water from a cooling tower enters the casting mold and provides cooling to allow the molten aluminum to solidify in the mold prior to exit. The mold cooling water passes through a screen with 1 mm (0.04 in.) perforations around each billet mold. Past history has shown that these screens would have to be removed every 4-5 days of production due to buildup of rust flakes, pipe scale, algae and oils before resuming production. In an effort to increase production and reduce this required downtime Noranda installed automatic self-cleaning filters with 300 micron (0.012 in.) weave-wire screens in February of 2000 to filter the water flow going to the mold tables. Average flow was 364 m<sup>3</sup>/hr (1600 gpm) at 5 bars (75 psi). Since the filters have been installed, the mold tables have been going at least 20 days between routine cleaning cycles with only one routine filter maintenance inspection over the past five years.





3 Chrysler  
Irvine, CA 92618  
T 925-609-2180  
F 949-455-7492

11/24/2010

### SUMMARY

Fully automatic self-cleaning screen filters provide an economical means of removing suspended solids down to 10 microns from cooling tower water. The use of weave-wire screens as the filtering media provides a positive removal system eliminating all particles larger than the filtration degree of the screen from the cooling system. The efficient suction scanning principle allows the filter cake to be removed completely from the screen surface within seconds without physically touching the cake or screen. During the suction scanning cleaning cycle the filtration process is uninterrupted; thereby, providing filtered water downstream of the filter at all times, eliminating the need for duplex systems. Water and chemical losses are kept to a minimum, and organic and inorganic solids are removed with equal efficiency. Automatic self-cleaning screen filters lend themselves to many industrial, commercial and power generation cooling tower applications.

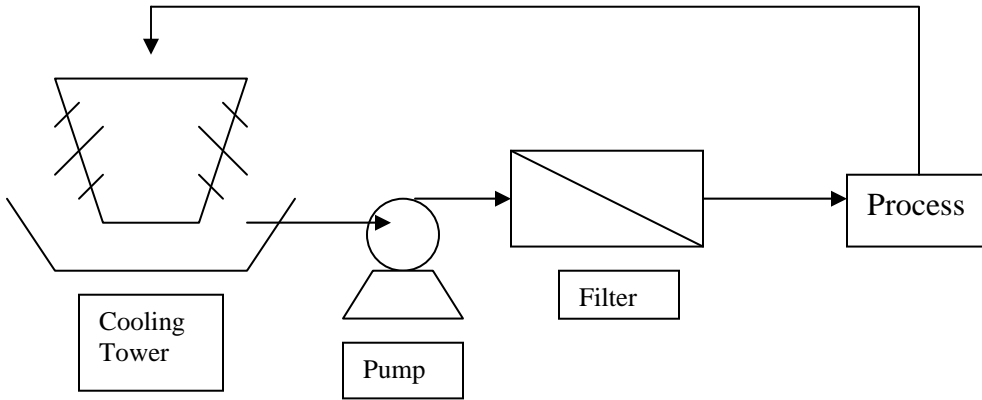

Figure 1. Full Flow Filtration

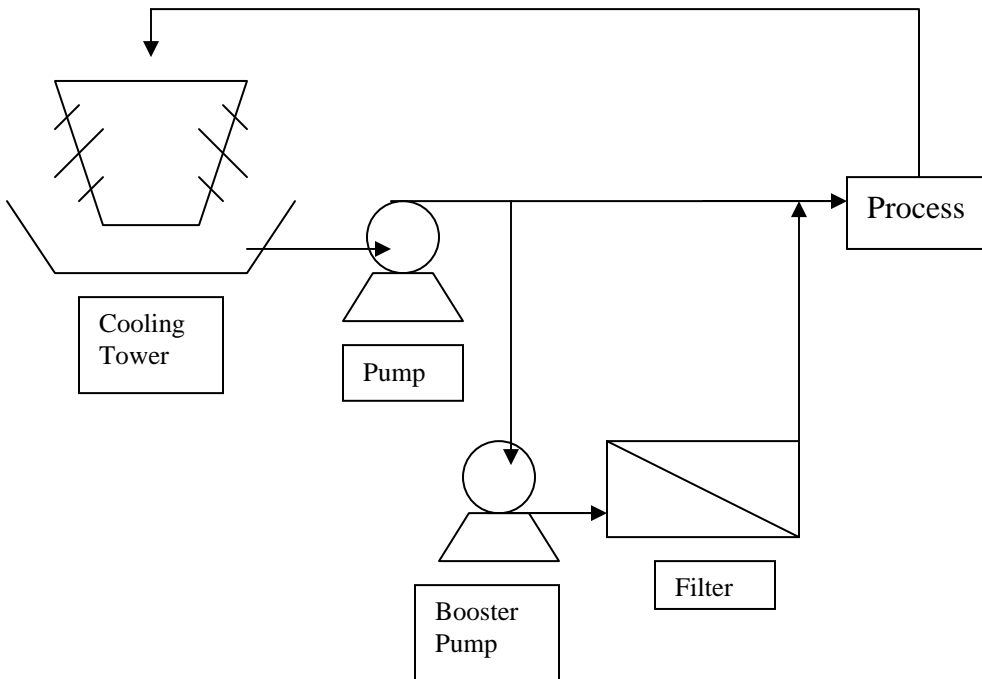

Figure 2. Side-stream Filtration with Booster Pump

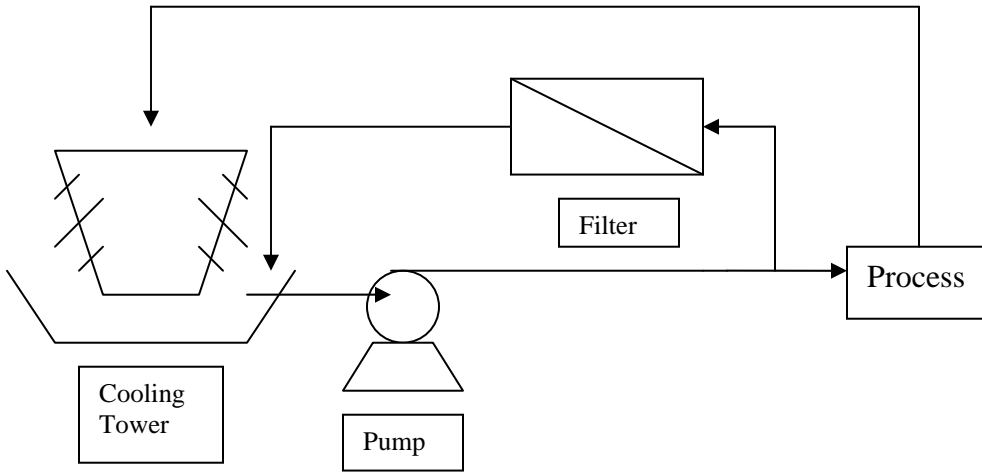

Figure 3. Simple Side-stream Filtration

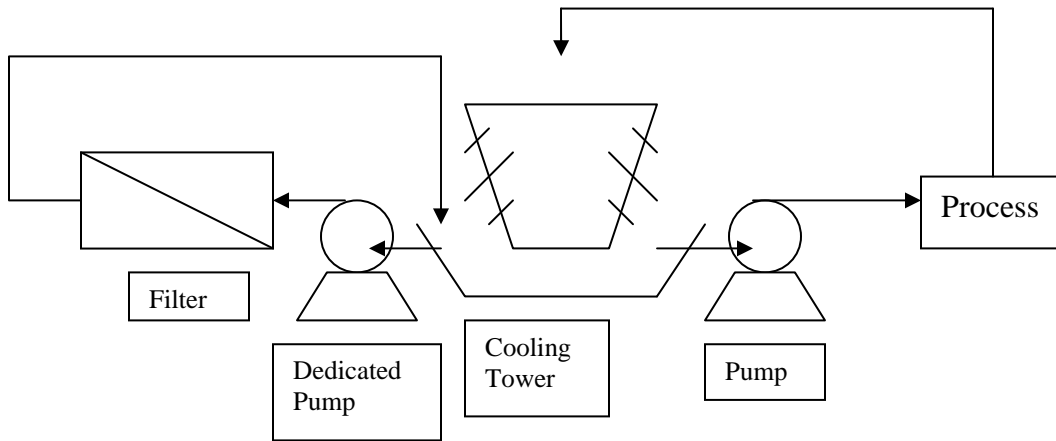
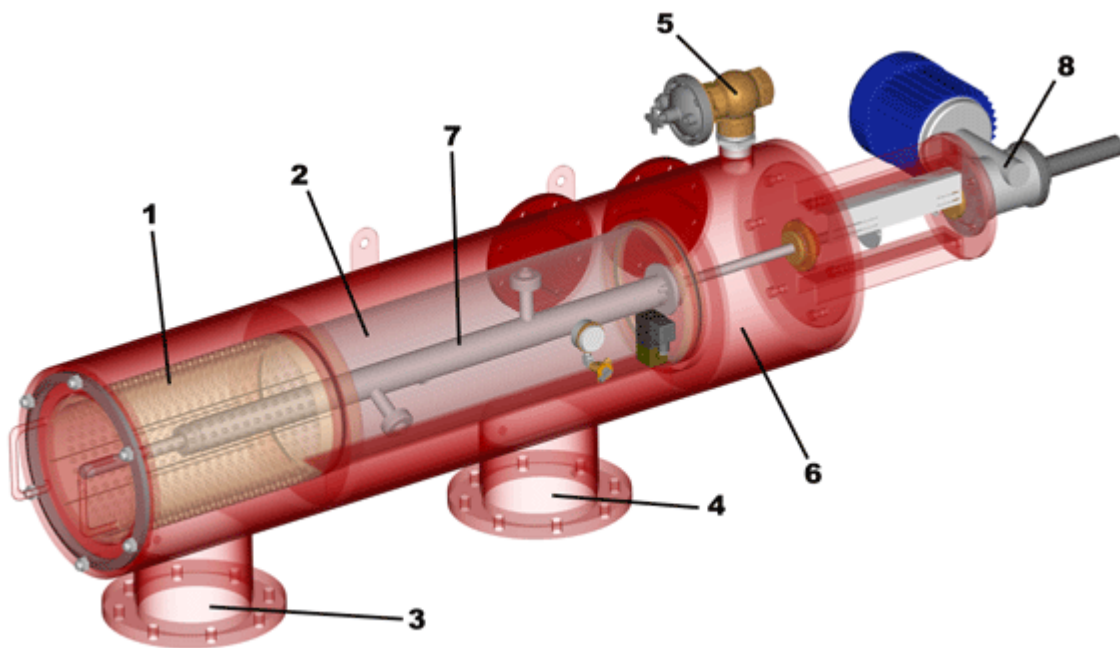

Figure 4. Side-stream Filtration with a Dedicated Pump

1. Course Screen Filter Element
2. Fine Screen Filter Element
3. Inlet Connection
4. Outlet Connection
5. Rinse/Flush Valve
6. Flushing Chamber
7. Suction Scanner/HE Nozzle Assy
8. Motor Drive



**Figure 5. GTE Automatic Screen Filter Cut-A-Way**

Foul Thickness and Resulting Increase in Energy Use*:		
Scale Thickness (in)	Foul Factor (hrft <sup>2</sup> F/BTU)	Energy Increase %
0.006	0.0005	5.3
0.012	0.001	10.6
0.024	0.002	21.5
0.036	0.003	32.2
0.048	0.004	43.0
Increased Energy use means <b>Decreased Efficiency</b> and <b>Higher Costs</b> .		
<b>*Data from Carrier Corp.</b>		

**Table 1. Cooling Efficiency**

ACKNOWLEDGEMENTS

REFERENCES

1. Legionellosis Guideline: Best Practices for Control of Legionella. Cooling Technology Institute Guidelines, February 2000.
2. Cooling Tower Water Treatment – Part II. Carolyn Bobby, Ron Ellis, John Hermon, Jean Lev, Jim Mick, Joe Ronco, Chuck Schissler and Dave Willetts. J.L. Hermon & Associates, Englewood, CO; January 2001.
3. For Industrial Process Fluids. Lakos Liquid - Solids Separation Systems, Fresno, CA; Brochure LS-636B (Rev. 11/02).
4. Media Filters For Trickle Irrigation In Florida. Dorota Z. Haman, Allen G. Smajstrla and Fedro S. Zazueta. Fact Sheet AE-57, University of Florida Cooperative Extension Service, IFAS. November 1994.
5. Self-Cleaning Pre-Filtration for R.O. and other Membrane Systems. Marcus N. Allhands. Proceedings, Fourteenth Annual Technical Conference - Science and Technology of Filtration and Separation for the 21<sup>st</sup> Century, American Filtration & Separations Society, Tampa, Florida May 1-4, 2001.
6. Brian Cooper, Cold Mill Electrical Supervisor, Nucor Steel, RR #2, Box 311, Crawfordsville, IN 47933. (765) 361-2213
7. Roger Parker, Process Engineer or Neil Priggel, Value Added Manager, Noranda Aluminum, Inc., P.O. Box 70, St. Jude Industrial Park, New Madrid, MO 63869. (573) 643-2361

Marcus N. Allhands, Ph.D., P.E.  
Application Engineer  
P.O. Box 261  
Lewisville, IN 47352

## **SIDE STREAM FILTRATION – A CASE STUDY**

### **Introduction**

Prior to the era of the *Green Movement* and the recognition of sustainability involving energy and natural resources, proactive building managers were already addressing the initiatives to reduce electricity and water consumption. These reductions are producing a more profitable bottom-line by investing in efficient technologies. Fortunately, these practices also conform or align themselves with the requirements to meet LEED (Leadership of Energy and Environment Design) certifications and the marketing value perception associated with that achievement. Successful and measurable building energy saving techniques benefit future projects by reducing the learning curve for design and engineering teams engaged in this business environment.

USGBC (United States Green Building Council) states that buildings use 70% of the electricity generated in the United States. This usage is broken down into three major categories; lighting 33%, chiller/cooling 25%, boilers/heating 23%, and all other building uses 19%. The U.S. Geological Survey estimates that the United States uses 400 billion gallons of water per day. The operation of buildings including landscaping accounts for approximately 47 billion gallons per day - 12% of total use. Not only is the purchase of potable water a cost concern, but in most cases the fees for waste water treatment is even costlier resulting in a higher negative impact for the building operating budgets. So, the motivation is very high to find solutions and reasonable paybacks for investing or modifying building infrastructure. The primary focus of this case study involves the chillers/cooling systems and associated water usage.

### **Amway Grand Plaza Hotel**

The Amway Grand Plaza is a 29-story, 4-star, 4-diamond luxury hotel located on the Grand River waterfront in Grand Rapids, MI. Guests are treated to an elegant Beaux Arts atmosphere straight out of the 1920s, when the hotel was named one of the 10 finest in America.

To remain competitive and cost effective the Amway Grand Plaza and their TEAM of engineers are always in the search for energy savings and being environmentally proactive. Like most major metropolitan cities, Grand Rapids water usage and energy consumption are the first things on the minds of building managers.

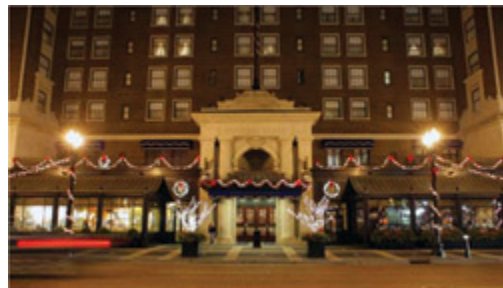

The Amway Grand Plaza.

Cooling towers have a great effect on water and energy consumption that are most overlooked as a potential candidate to save on operating capital. The primary purpose of cooling towers located outside the buildings are for HVAC (Heating Ventilation & Air Conditioning) applications and rejecting heat from the chillers used in process of cooling the buildings. The quality of the water has a great effect on the efficiency of the tube bundles, which are the primary interface for the heat-exchange process. Dissolved solids from the water can precipitate-out forming particles, if not remove will form an insulating barrier in the side walls of the tubes. These particulates can also settle inside the tubes reducing the thermal dynamic efficiency of the chillers and the tube coefficient, or reducing the ability to transfer heat, causing the chiller to work harder.

11/24/2010

Special Note - Cleaner process water is even more important now especially with the new air conditioning equipment containing refrigerant gases that do not deplete the ozone layer and contribute to global warming. These new refrigerants are less efficient at heat transfer compared to the older CFC (chlorofluorocarbons) that are banned by the Montreal Protocol treaty on January 1, 1989.

The cooling towers outside the building circulate air and water for the purpose of heat rejection. During this process cooling towers become unintentional efficient air-scrubbers, removing air-borne debris, adding more contaminants and suspended solids to the system, intensifying the problem. These suspended solids become denser as water evaporates from the towers and if allowed to accumulate, can plug the tubes of the heat-exchangers. To keep the heat transfer effective longer; chemicals are added to separate the dissolved solids out of solution, control suspended solids, and to maintain the proper pH and physical properties of the water. Once the solids reach a high density the chemicals become ineffective, it is common to flush/dilute them out by adding more fresh water and dumping the dirtier water to a drain –called a tower basin blow-down. After the new water is added, more chemicals are injected to combat the solids, and maintain the pH and physical properties of the water. It was obvious that not only high water usage was an issue, but the added expense of chemicals needed to be addressed.

The hotel management decided to seek a solution. Efrain Melendez, Physical Plant Manager, contacted Systemcore, Inc. and Mike Boyd with the Macomb Group M.E.R.I.T. (Macomb Energy Resource Integration Team) in Grand Rapids, to find a compact filtration technology that would be effective and efficient without placing new demands on his maintenance staff.

### The Solution

After discussion and checking references with colleagues at hotels that faced similar challenges, Melendez selected an automatic, self-cleaning filter.

The filter similar to the one pictured below was outfitted with a 80-micron, 316L stainless steel



The installed filter is "green technology."

permanent screen and was installed in the main mechanical room of the building for all 6 towers. Compact and virtually maintenance-free, the unit was effective at filtering out suspended particles even during times of high dirt content in the air. Constructed from NSF materials, the filter is "green" technology, with a minimal footprint, low energy demand and minimal water use—less than 1% of the total flow is needed for back flushing the system. This reduces the system's water footprint; just as the filter's compact size reduces its physical footprint. Wastewater generated by the cleaning technology is cut in half compared to older scanner-cleaning technology, saving both water and sewer disposal costs.

Unlike cartridge filters, there are no cartridges elements to replace and discard, minimizing labor demands and eliminating the cost of consumables.



3 Chrysler  
 Irvine, CA 92618  
 T 925-609-2180  
 F 949-455-7492

11/24/2010

In addition to the permanent screen element, the filter contains a high-efficiency (HE) cleaning mechanism, consisting of a specially designed suction scanner. HE-focused back flush technology takes advantage of simple physics using half of the water during the cleaning process compared to other suction scanner technologies.

When a preset pressure differential is reached between the two sides of the screen (typically 7 psi), an outlet valve connected to the suction scanner opens. Water and filter cake are pulled through the suction scanning nozzles at a velocity of 50-feet-per-second by the pressure differential between operating and atmospheric pressure. The scanner operates in a spiral pattern, ensuring that the suction nozzles clean the entire screen in a 16-second back flush cycle. The process takes place without interrupting the operation of flow to equipment downstream of the filter.

The cleaning nozzle and screen media are designed to allow impingement between the two surfaces during the cleaning process. The nozzle automatically adjusts itself along the screen surface to compensate for any irregularities, minimizing tangential flow and maximizing the cleaning process at the nozzle orifice.

**Results**

Within a month of selecting the system, the filter was onsite, installed and commissioned. Melendez is enthusiastic about the system. "Finally," he said, "a product that really works as stated by the manufacturer." The simplicity of design, cleaning efficiency and reliability based on just a few moving parts keep the system virtually maintenance-free. The savings of the new filtration system included a reduction in water, sewer, and chemical expenses. This allows for investment in other energy and environmental friendly systems while being cost effective. The improved efficiency of the system adds value to Amway Grand Plaza Hotel.

The Amway has 2676 tons of cooling operating at a rate of 300 GPM on the side stream with a total tower water flow of 5672 GPM. The Filter was installed the first of the season 2009:

SYSTEMS OPERATION SUMMARY											
UTILITY SEASONAL		2008 Pre-Filtration		2009 Post Filtration		2010 Post Filtration		Percent Reduction		Capital Recovery	
		June	July	June	July	June	July	June	July	June	July
		Aug	Aug	Aug	Aug	Aug	Aug	Aug	Aug	Aug	
Electrical (KWH)		1,676,400		1,563,600		1,646,400		4%		\$4,998.00	
Water (GAL)		2,331,516		340,340		504,900		82%		\$26,586.00	
CHEMICAL TREATMENT (GAL)		825		275		275		66%		\$14,000.00	
									2-YR Average		\$45,584.00





**Special Note:**

According to the national weather data report below the number of degree days in 2010 increased by 20% for the peak seasonal period of June, July, & August, however the electrical consumption for 2010 is still 2% below the usage for 2008. This information further corroborates the efficiency gains by side-stream filtration.

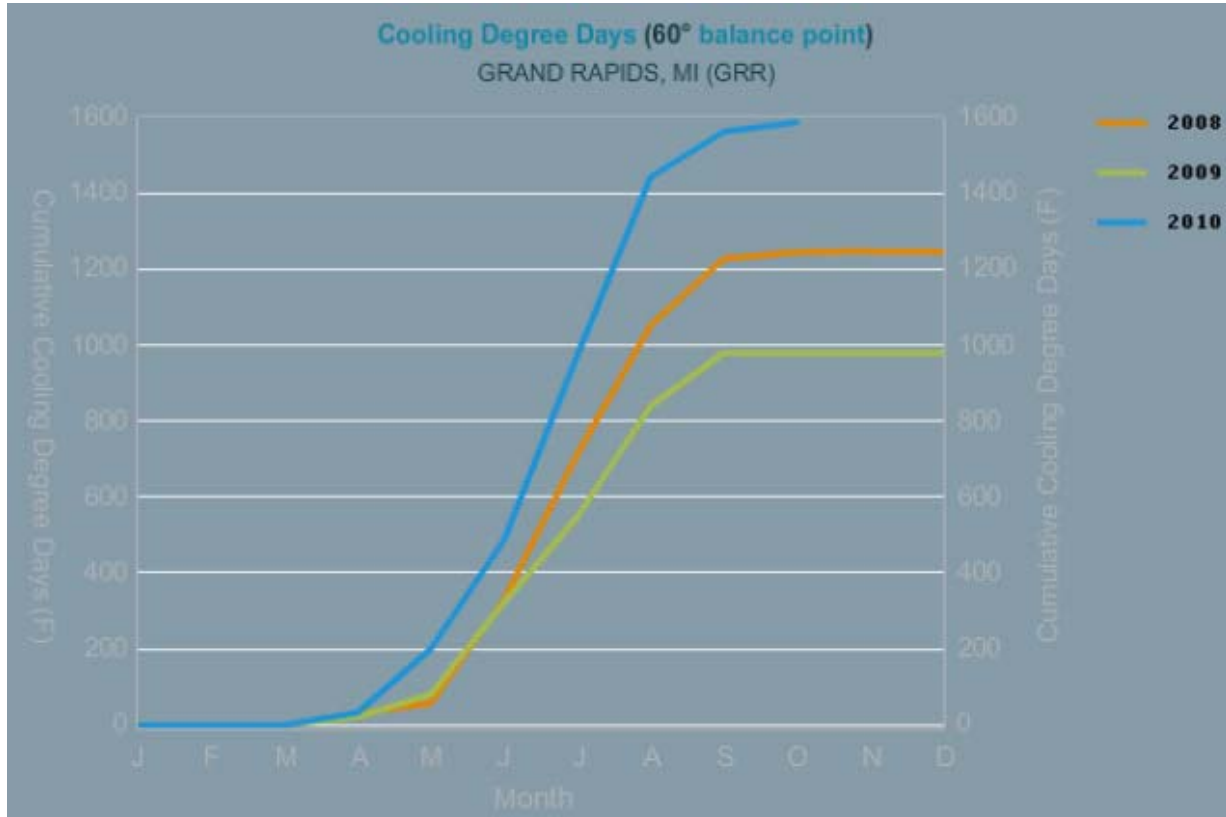



APPENDIX – Drawings & Photographs

